



IVS Front Panel



IVS Back Panel

### HIGHLIGHTS

- 1-channel audio/video encode/decode streamer over TCP/IP
- 30 frames per second, D1 resolution
- TI DaVinci™ DM6446 Dual-Core DSP with ARM926
- H.264 and MJPEG codecs pre-installed\*
- Supports TI and 3<sup>rd</sup> Party codecs including H.264 BP/MP, MPEG-4/H.263, MPEG-2, and MJPEG
- Video analytics-capable
- Supports unicast and multicast
- Supports audio mic interface and G.711 encoding
- 10/100 Ethernet TCP/IP compressed video stream
- Power-over-Ethernet 802.3af-compliant PD controller with integrated DC/DC converter
- Real-Time Embedded Linux
- Decodes to any networked PC running a decoder such as QuickTime or VLC Player
- Browser-based utility allows configuration of settings and parameters
- RTP/RTSP over UDP/TCP transport
- Compact form factor
- 12V DC, 4.5W max
- RoHS compliant
- Available as evaluation unit or production license with fully licensable design

### OVERVIEW

Nuvation's Intelligent Video Server (IVS) is a reference design for a 1-channel audio/video encode/decode streamer which can adapt a standard CCTV analog camera into an Internet Protocol (IP) streamer. The reference design features TI's DaVinci™ DM6446 DSP, TI Digital Media software codecs, Embedded Linux, optional video analytics, and a compact mechanical enclosure.

### PACKAGES

- **Evaluation Units\*** are intended for OEMs interested in evaluating the reference design for production license. Users can plug-and-play the IVS right out of the box, and experiment with different codec settings. Advanced users may experiment with reprogramming the DM6446 with their own custom software builds.
- **Production Licenses\*** are intended for full manufacturing and IP control including rights to make derivative products.

*\*Package details are listed on page 3.*

### SOFTWARE & DRIVERS

- Runs Montavista Linux with TI DaVinci™ driver support
- Encoder firmware application that encodes/decides audio-video streams in real-time
- Decoder comes with audio-video synchronizing mechanisms for proper playback
- *thttpd* lightweight web server runs a browser utility for easy camera configuration
- Driver support for USB, video, audio and UART RS-232 communication

### EXTERNAL INTERFACES

#### Front Panel:

- V-in: Video input (BNC)
- V-out: Video output (BNC)
- L-in: Stereo audio line input (1/8" jack)
- L-out: Stereo audio line output (1/8" jack)
- Mic: Microphone input (1/8" jack)
- PTZ: Pan/Tilt/Zoom (RS-232)

#### Back Panel:

- Ethernet (RJ-45)
- Analog Video - NTSC / PAL (BNC)
- USB 2.0
- Auto-Iris
- Joystick
- Two dip switches (can be SW-enabled)

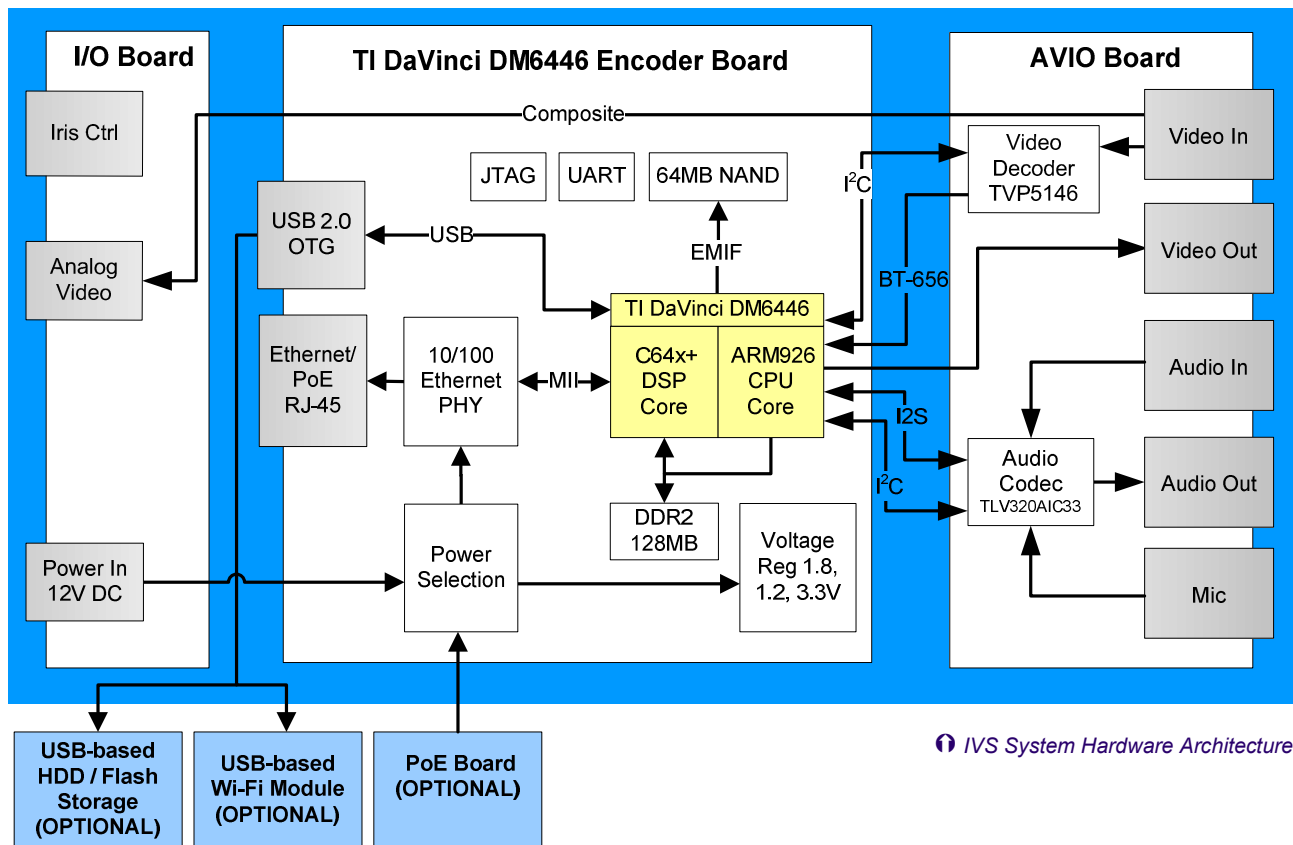

## SYSTEM ARCHITECTURE

An external video/audio source (eg. camera) can be connected to the IVS through to stream the video on a network. The source is connected through the IVS front panel. Video and audio connect directly to the AVIO board inside the IVS.

The AVIO board receives composite video through a BNC connector. Able to decode both NTSC and PAL video formats, a TVP5146 video decoder converts the video to 10-bit BT.656 and sends it to a TI DaVinci™ processor on the Encoder board. The video output connector passes NTSC / PAL analog video received from the DaVinci™ processor. Stereo audio input, output, and mic connections run through an audio codec, and on to a bi-directional I2S bus to the DaVinci™ processor. Both the video and audio codecs are controlled through an I<sup>2</sup>C interface.

Within the DaVinci™, the incoming BT.656 video stream is processed by the Video Processing Front End (VPFE) and sent to the C64+ DSP for encoding. The DSP encodes it with the chosen video codec and passes the data back to the ARM. The ARM then packetizes the data using the RTP/RTSP over UDP/TCP protocol and sends the stream to the Ethernet PHY chip for transmission over the network.

A web server running on the ARM within the DaVinci™ allows users on the network to configure IVS settings through a browser utility.

## SYSTEM COMPONENTS

- AVIO Board
  - Video in and video out BNC connectors
  - Audio line in, line out, and mic connectors
  - Pan/Tilt/Zoom control, RS-232 connector
  - Video decoder TVP5146
  - Audio codec TLV320AIC33
- TI DaVinci™ DM6446 Encoder Board
  - TI DaVinci™ DM6446 with C64x+ DSP and ARM926E
  - 2 banks of DDR2, 128MB
  - 64MB NAND Flash
  - UART Port
  - JTAG Port
  - 10/100 Ethernet MAC routed to Ethernet PHY board
  - USB 2.0 routed to OTG connector on IO board
  - No blind or buried vias
  - RJ-45 Ethernet
  - USB 2.0 OTG (SW configured as USB master)
  - Includes connector for optional PoE board (ordered separately)
- I/O Board
  - NTSC/PAL video pass-through, BNC connector
  - Power in, 12V
  - Auto-Iris
  - Joystick
  - Dip switches

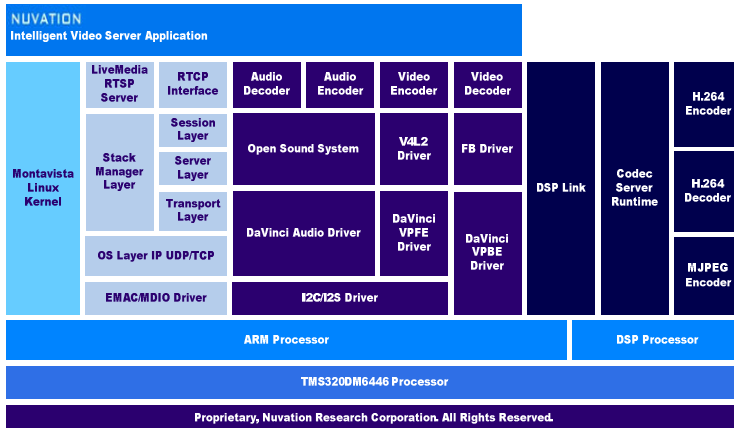

IVS Software Architecture

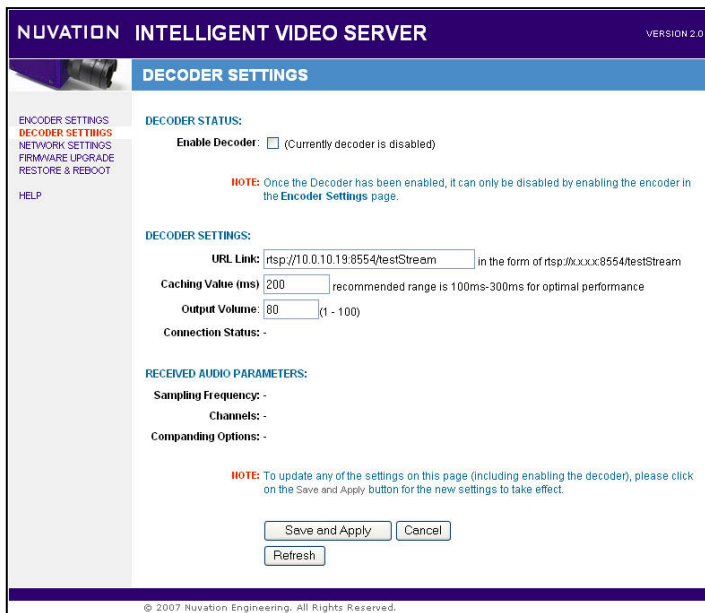

Browser Utility Screen Shot

### TI DAVINCI™ DM6446 SOFTWARE OPTIONS

- Pre-programmed TI eXpressDSP Digital Media software (evaluation versions):
  - H.264 BP encode/decode
  - MJPEG encode
  - G.711 encode/decode
- TI DaVinci™ DM6446 also supports H.264 MP, MPEG-4/H.263, and MPEG-2 video encoders and a full range of audio encoders from TI and 3<sup>rd</sup> Parties.
- Full Embedded Linux 2.6 running on an ARM926 coprocessor within the DaVinci™
- Video content analytics capable, custom or licensable

### DSP SOFTWARE

- The DSP runs the complex algorithms required to encode the raw video into the various video codec formats
- The ARM is responsible for managing the digital video interface and the web server

### BROWSER UTILITY

Included browser-based utility enables users to changes settings, test parameters, update camera software, and change IP and MAC addresses. Served from the ARM coprocessor within the DaVinci™, the following groups of parameters can be configured:

- Encoder Settings
- Decoder Settings
- Network Settings
- Firmware Upgrade
- Restore & Reboot

### EVALUATION UNIT PACKAGE

The evaluation unit package includes:

- IVS pre-programmed with TI's H.264BP encoder and MJPEG codec
- Camera lens
- Ethernet cable and DC power adapter
- Nuvation-optimized Linux Board Support Package
- IVS Browser Utility
- Quick Start Guide (QSG)
- Technical Reference Manual (TRM)

### PRODUCTION LICENSE PACKAGE

Licensees receive entire design source code package:

- Design schematics
- Bills of materials
- Layout databases
- Linux source code
- Hardware and software specification documents
- Enclosure CAD mechanicals
- Manufacturing instructions

### DIMENSIONS

- L: 4.25" (108mm), H: 1.7" (43mm), W: 1.8" (47mm)

### CONTACT

EMAIL [IP@NUVATION.COM](mailto:IP@NUVATION.COM)  
 WEB [WWW.NUVATION.COM](http://WWW.NUVATION.COM)  
 TEL +1.408.228.5580  
 FAX +1.408.228.5590